

## N-Channel 100-V<sub>(D-S)</sub> SGT MOSFET

PRODUCT SUMMARY		
B <sub>VDSS</sub> (V)	R <sub>DS(on)</sub> (mΩ)(MAX)	I <sub>D</sub> (A)
100	4.2@V <sub>GS</sub> =10V	150

### TO220 Pin Configuration

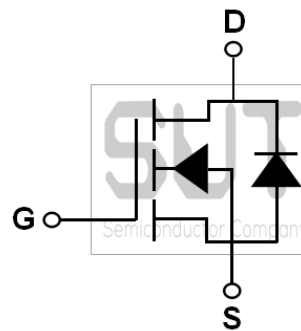
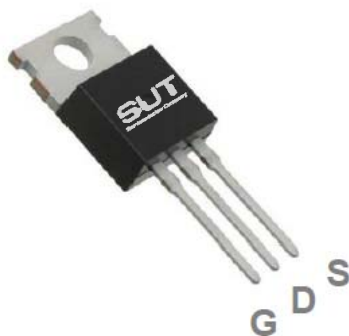

### ABSOLUTE MAXIMUM RATINGS(T<sub>C</sub>=25°C UNLESS OTHERWISE NOTED)

Parameter	Symbol	Rating	Units
Drain-Source Voltage	V <sub>DS</sub>	100	V
Gate-Source Voltage	V <sub>GS</sub>	+20/-12	V
Drain Current-Continuous (T <sub>C</sub> =25°C)	I <sub>D</sub>	150	A
Drain Current-Continuous (T <sub>C</sub> =100°C)		95	A
Drain Current-Pulsed <sup>1</sup>	I <sub>DM</sub>	600	A
Single Pulse Avalanche Energy <sup>2</sup>	EAS	378	mJ
Single Pulse Avalanche Current <sup>2</sup>	IAS	87	A
Power Dissipation (T <sub>C</sub> =25°C)	P <sub>D</sub>	275	W
Power Dissipation-Derate above 25°C		2.22	W/°C
Storage Temperature Range	T <sub>STG</sub>	-50 to 150	°C
Operating Junction Temperature Range	T <sub>J</sub>	-50 to 150	°C

### THERMAL CHARACTERISTICS

Parameter	Symbol	Typ.	Max.	Unit
Thermal Resistance Junction to ambient	R <sub>θJA</sub>	---	62	°C/W
Thermal Resistance Junction to Case	R <sub>θJC</sub>	---	0.45	°C/W

ELECTRICAL CHARACTERISTICS (T <sub>J</sub> =25°C UNLESS OTHERWISE NOTED)						
Parameter	Symbol	Test Condition	Min.	Typ.	Max.	Unit
<b>Off Characteristics</b>						
Drain-Source Breakdown Voltage	BV <sub>DSS</sub>	V <sub>GS</sub> =0V, I <sub>D</sub> =250uA	100	---	---	V
Drain-Source Leakage Current	I <sub>DSS</sub>	V <sub>GS</sub> =0V, V <sub>DS</sub> =100V, T <sub>J</sub> =25°C	---	---	1	uA
		V <sub>GS</sub> =0V, V <sub>DS</sub> =80V, T <sub>J</sub> =85°C	---	---	10	uA
Gate-Source Leakage Current	I <sub>GSS</sub>	V <sub>GS</sub> =20V, V <sub>DS</sub> =0V	---	---	100	nA
<b>On Characteristics</b>						
Static Drain-Source On-Resistance	R <sub>DS(ON)</sub>	V <sub>GS</sub> =10V, I <sub>D</sub> =20A	---	3.5	4.2	mΩ
Gate Threshold Voltage	V <sub>GS(th)</sub>	V <sub>GS</sub> =V <sub>DS</sub> , I <sub>D</sub> =250uA	2.0	---	4.0	V
Forward Transconductance	g <sub>fs</sub>	V <sub>DS</sub> =10V, I <sub>D</sub> =3A	---	20	---	S
<b>Dynamic and Switching Characteristics</b>						
Total Gate Charge <sup>3, 4</sup>	Q <sub>g</sub>	V <sub>GS</sub> =10V, V <sub>DS</sub> =80V, I <sub>D</sub> =10A	---	110	165	nC
Gate-Source Charge <sup>3, 4</sup>	Q <sub>gs</sub>		---	11.5	18	
Gate-Drain Charge <sup>3, 4</sup>	Q <sub>gd</sub>		---	28	42	
Turn-On Delay Time <sup>3, 4</sup>	T <sub>d(on)</sub>	V <sub>GS</sub> =10V, V <sub>DD</sub> =50V, R <sub>G</sub> =6Ω, I <sub>D</sub> =1A	---	23	46	ns
Rise Time <sup>3, 4</sup>	T <sub>r</sub>		---	32	64	
Turn-Off Delay Time <sup>3, 4</sup>	T <sub>d(off)</sub>		---	157	320	
Fall Time <sup>3, 4</sup>	T <sub>f</sub>		---	115	230	
Input Capacitance	C <sub>iss</sub>	V <sub>GS</sub> =0V, V <sub>DS</sub> =25V, F=1MHz	---	6680	13300	pF
Output Capacitance	C <sub>oss</sub>		---	1690	3380	
Reverse Transfer Capacitance	C <sub>rss</sub>		---	78	156	
Gate resistance	R <sub>g</sub>	V <sub>GS</sub> =0V, V <sub>DS</sub> =0V, F=1MHz	---	1.9	---	Ω
<b>Drain-Source Diode Characteristics and Maximum Ratings</b>						
Continuous Source Current	I <sub>S</sub>	V <sub>G</sub> =V <sub>D</sub> =0V, Force Current	---	---	150	A
Pulsed Source Current	I <sub>SM</sub>		---	---	300	A
Diode Forward Voltage	V <sub>SD</sub>	V <sub>GS</sub> =0V, I <sub>S</sub> =1A, T <sub>J</sub> =25°C	---	---	1.0	V

Note :

1. Repetitive Rating : Pulsed width limited by maximum junction temperature.
2. V<sub>GS</sub>=10V, V<sub>DD</sub>=25V, L=0.1mH, I<sub>AS</sub>=87A, R<sub>G</sub>=25Ω, Starting T<sub>J</sub>=25°C.
3. The data tested by pulsed, pulse width ≤ 300us, duty cycle ≤ 2%.
4. Essentially independent of operating temperature.

## 100V N-Channel MOSFETs

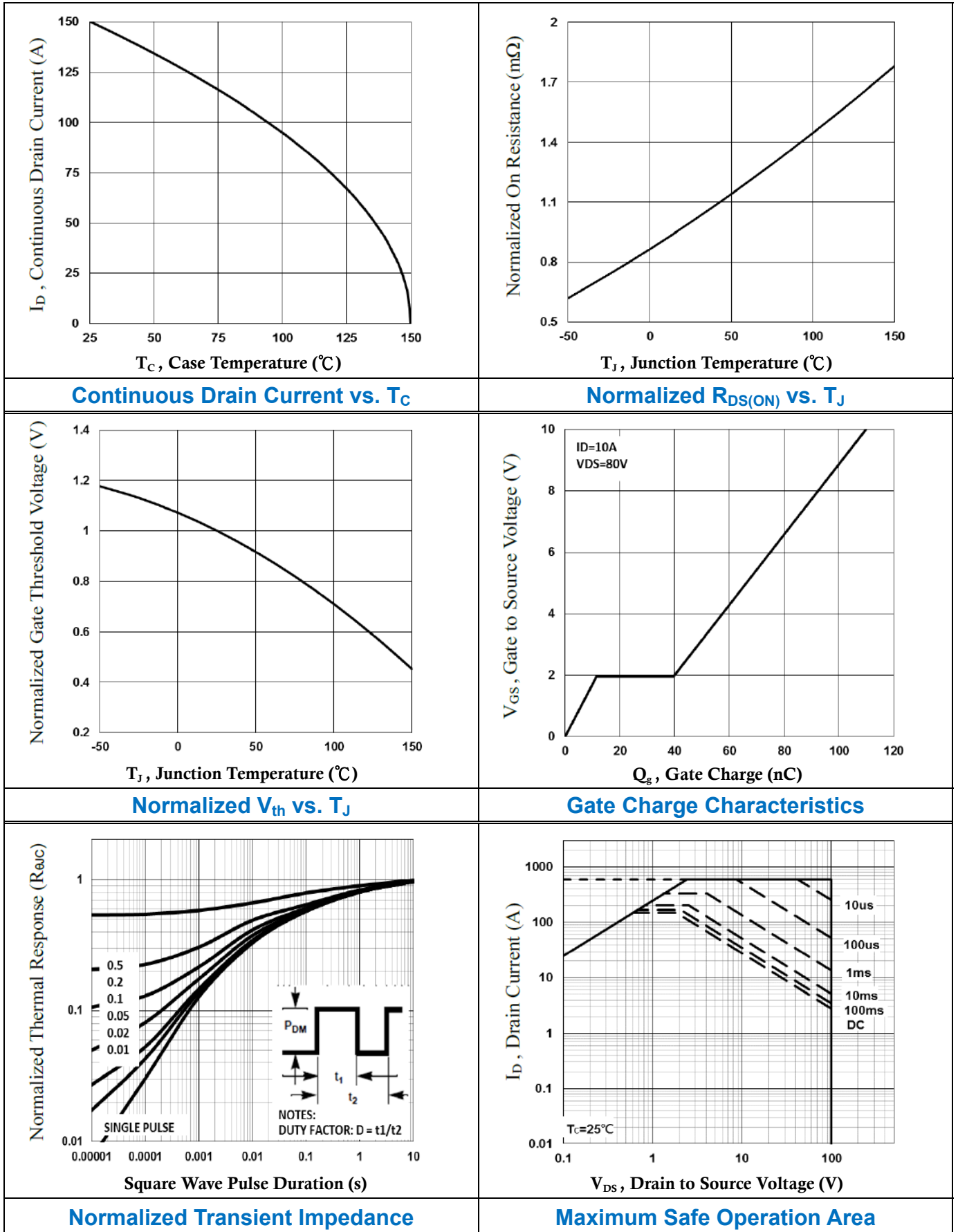

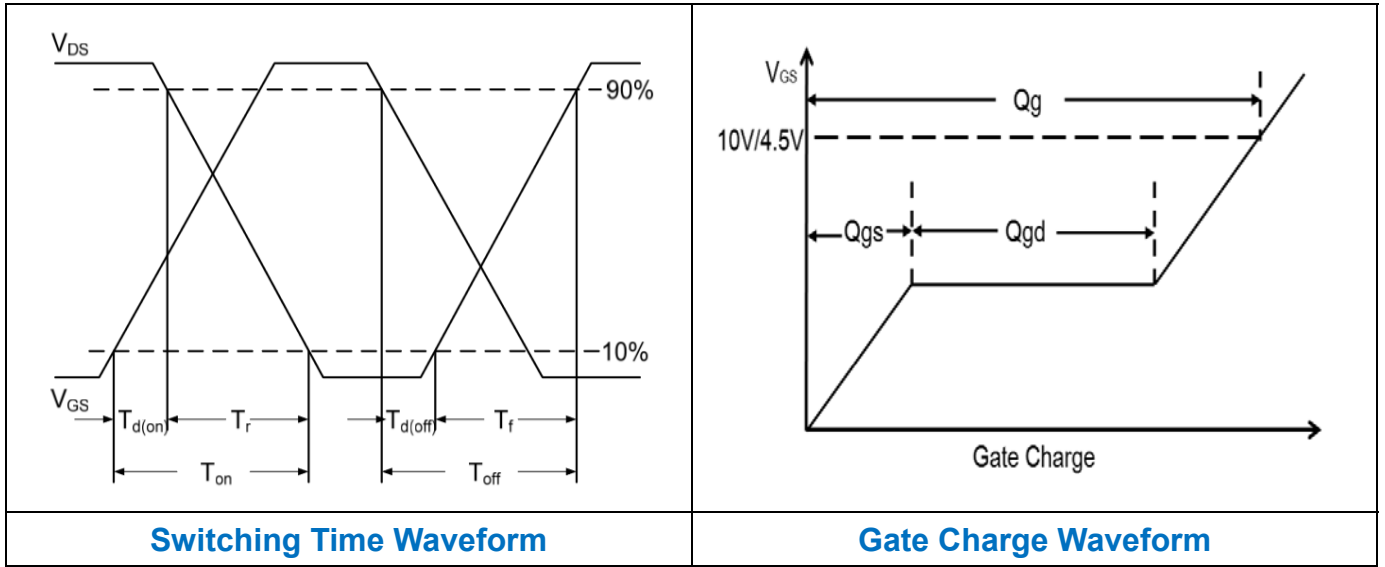

TO220 PACKAGE INFORMATION

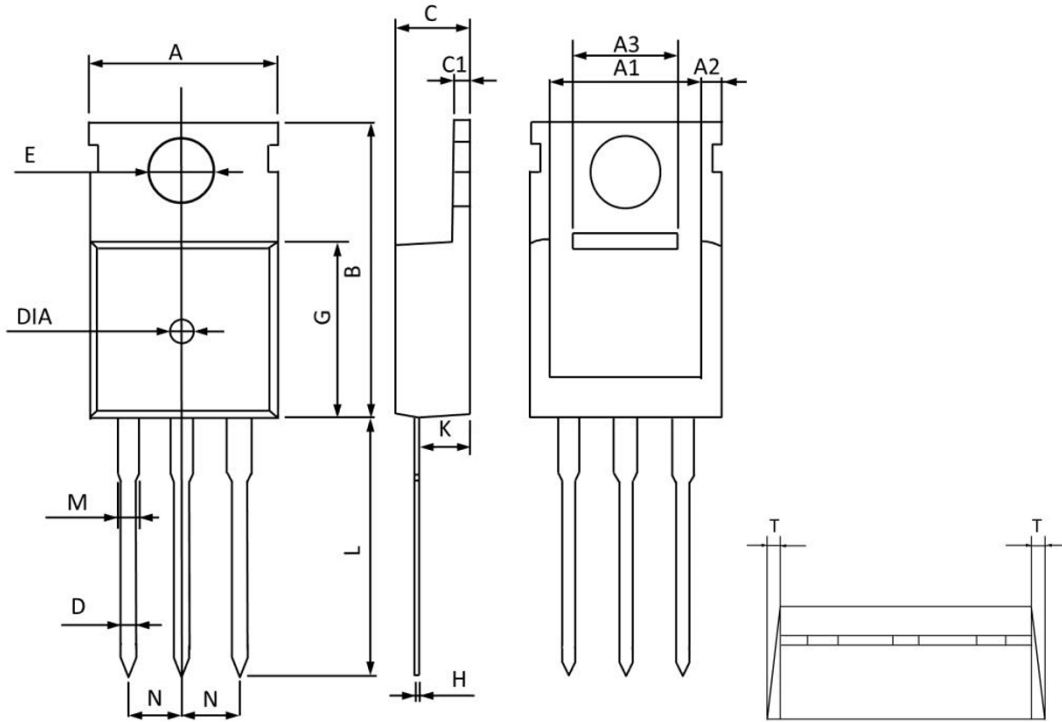

Symbol	Dimensions In Millimeters		Dimensions In Inches	
	MAX	MIN	MAX	MIN
A	10.300	9.700	0.406	0.382
A1	8.840	8.440	0.348	0.332
A2	1.250	1.050	0.049	0.041
A3	5.300	5.100	0.209	0.201
B	16.200	15.400	0.638	0.606
C	4.680	4.280	0.184	0.169
C1	1.500	1.100	0.059	0.043
D	1.000	0.600	0.039	0.024
E	3.800	3.400	0.150	0.134
G	9.300	8.700	0.366	0.343
H	0.600	0.400	0.024	0.016
K	2.700	2.100	0.106	0.083
L	13.600	12.800	0.535	0.504
M	1.500	1.100	0.059	0.043
N	2.590	2.490	0.102	0.098
T	W0.350		W0.014	
DIA	Ø1.500(TYP)	Deep0.200(TYP)	Ø0.059(TYP)	Deep0.008(TYP)