

N-Channel 100-V_(D-S) SGT MOSFET

PRODUCT SUMMARY		
B _{VDSS} (V)	R _{DS(on)} (mΩ)(MAX)	I _D (A)
100	9.2@V _{GS} =10V	12

SOP8 Pin Configuration

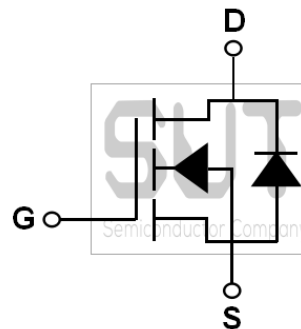
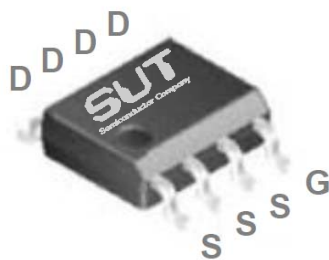

ABSOLUTE MAXIMUM RATINGS(T_C=25°C UNLESS OTHERWISE NOTED)

Parameter	Symbol	Rating	Units
Drain-Source Voltage	V _{DS}	100	V
Gate-Source Voltage	V _{GS}	+20/-12	V
Drain Current-Continuous(T _C =25°C)(Chip Limitation)	I _D	12	A
Drain Current-Continuous(T _C =100°C)(Chip Limitation)		7.6	A
Drain Current-Pulsed ¹	I _{DM}	48	A
Single Pulse Avalanche Energy ²	EAS	211	mJ
Single Pulse Avalanche Current ²	IAS	65	A
Power Dissipation (T _C =25°C)	P _D	5.0	W
Power Dissipation-Derate above 25°C		0.04	W/°C
Storage Temperature Range	T _{STG}	-50 to 150	°C
Operating Junction Temperature Range	T _J	-50 to 150	°C

THERMAL CHARACTERISTICS

Parameter	Symbol	Typ.	Max.	Unit
Thermal Resistance Junction to ambient	R _{θJA}	---	62	°C/W
Thermal Resistance Junction to Case	R _{θJC}	---	25	°C/W

ELECTRICAL CHARACTERISTICS (T _J =25°C UNLESS OTHERWISE NOTED)						
Parameter	Symbol	Test Condition	Min.	Typ.	Max.	Unit
Off Characteristics						
Drain-Source Breakdown Voltage	BV _{DSS}	V _{GS} =0V, I _D =250μA	100	---	---	V
BV _{DSS} Temperature Coefficient	ΔBV _{DSS} /ΔT _J	Reference to 25°C, I _D =1mA	---	0.054	---	V/°C
Drain-Source Leakage Current	I _{DSS}	V _{GS} =0V, V _{DS} =100V, T _J =25°C	---	---	1	μA
		V _{GS} =0V, V _{DS} =80V, T _J =125°C	---	---	10	μA
Gate-Source Leakage Current	I _{GSS}	V _{GS} =20V, V _{DS} =0V	---	---	100	nA
On Characteristics						
Static Drain-Source On-Resistance	R _{DS(ON)}	V _{GS} =10V, I _D =8.5A	---	7.6	9.2	mΩ
		V _{GS} =4.5V, I _D =4A	---	10.8	14	mΩ
Gate Threshold Voltage	V _{GS(th)}	V _{GS} =V _{DS} , I _D =250μA	1.2	1.6	2.5	V
V _{GS(th)} Temperature Coefficient	ΔV _{GS(th)}		---	-5.5	---	mV/°C
Forward Transconductance	g _{fs}	V _{DS} =10V, I _D =3A	---	11	---	S
Dynamic and Switching Characteristics						
Total Gate Charge ^{3, 4}	Q _g	V _{GS} =10V, V _{DS} =80V, I _D =8.5A	---	39.7	80	nC
Gate-Source Charge ^{3, 4}	Q _{gs}		---	5.4	10	
Gate-Drain Charge ^{3, 4}	Q _{gd}		---	11.2	22	
Turn-On Delay Time ^{3, 4}	T _{d(on)}	V _{GS} =10V, V _{DD} =50V, R _G =6Ω, I _D =1A	---	14.6	30	ns
Rise Time ^{3, 4}	T _r		---	21.5	44	
Turn-Off Delay Time ^{3, 4}	T _{d(off)}		---	54	108	
Fall Time ^{3, 4}	T _f		---	84.3	168	
Input Capacitance	C _{iss}	V _{GS} =0V, V _{DS} =25V, F=1MHz	---	2590	3800	pF
Output Capacitance	C _{oss}		---	690	1000	
Reverse Transfer Capacitance	C _{rss}		---	120	180	
Gate resistance	R _g	V _{GS} =0V, V _{DS} =0V, F=1MHz	---	1.43	---	Ω
Drain-Source Diode Characteristics and Maximum Ratings						
Continuous Source Current	I _S	V _G =V _D =0V, Force Current	---	---	12	A
Pulsed Source Current	I _{SM}		---	---	24	A
Diode Forward Voltage	V _{SD}	V _{GS} =0V, I _S =1A, T _J =25°C	---	---	1.0	V

Note :

1. Repetitive Rating : Pulsed width limited by maximum junction temperature.
2. V_{GS}=10V, V_{DD}=50V, L=0.1mH, I_{AS}=65A, R_G=25Ω, Starting T_J=25°C.
3. The data tested by pulsed, pulse width ≤ 300us, duty cycle ≤ 2%.
4. Essentially independent of operating temperature.

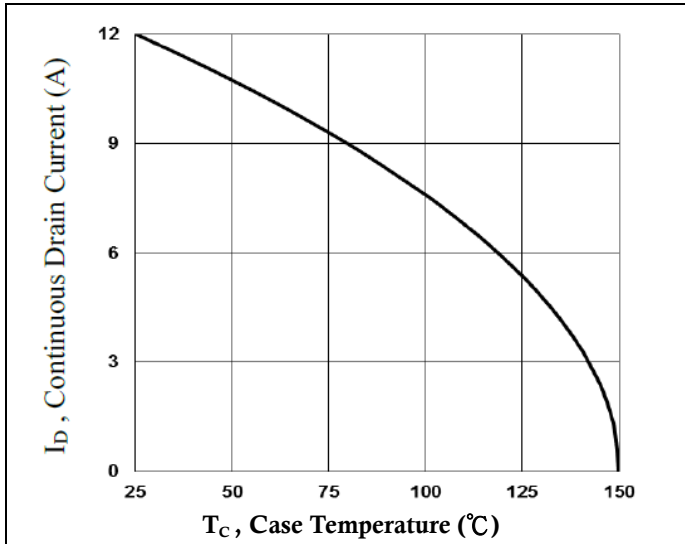

Continuous Drain Current vs. T_C

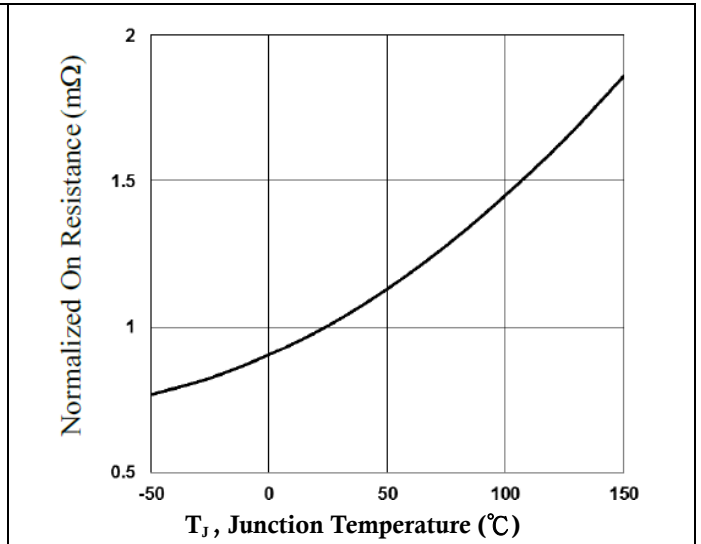

Normalized $R_{DS(ON)}$ vs. T_J

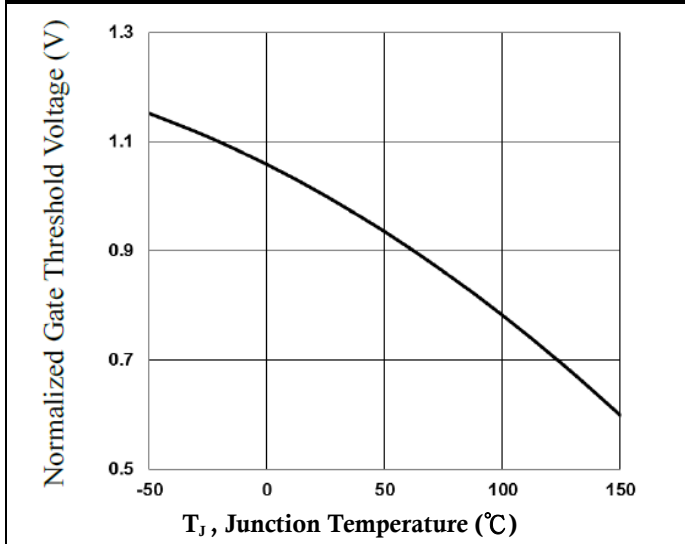

Normalized V_{th} vs. T_J

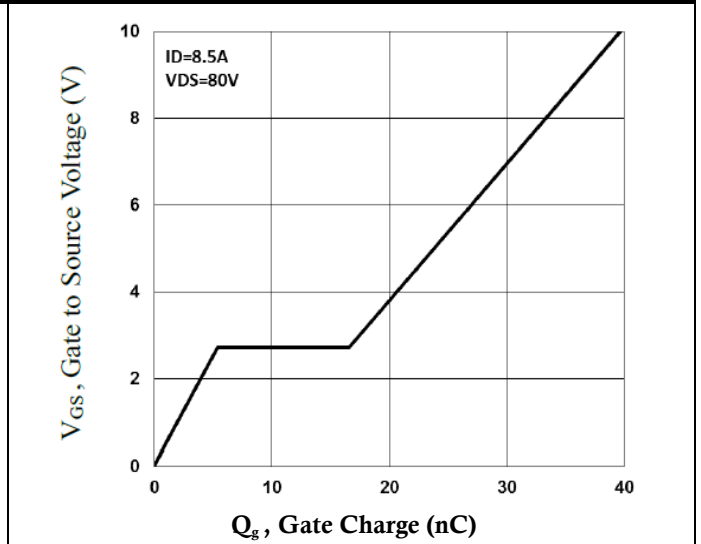

Gate Charge Characteristics

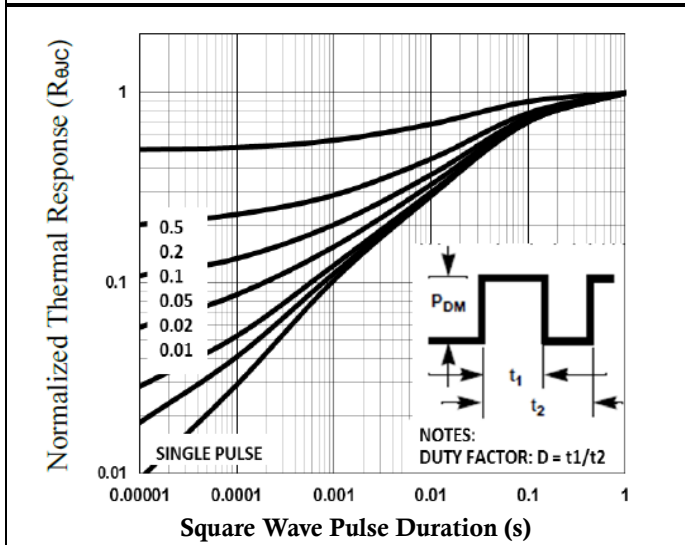

Normalized Transient Impedance

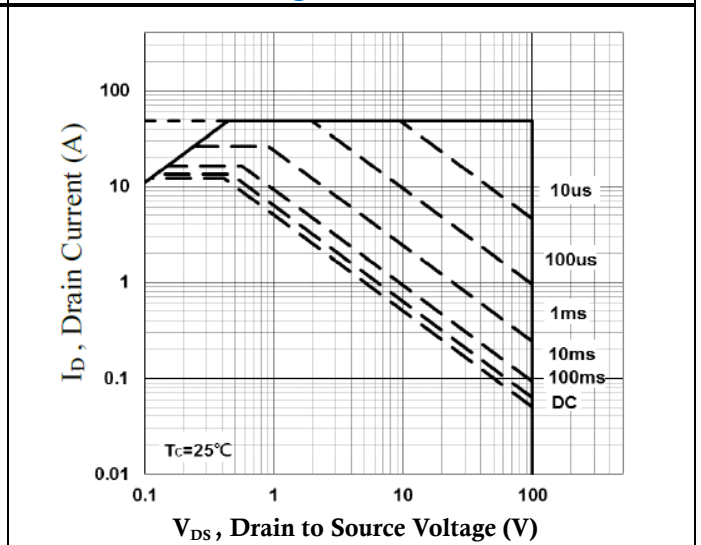

Maximum Safe Operation Area

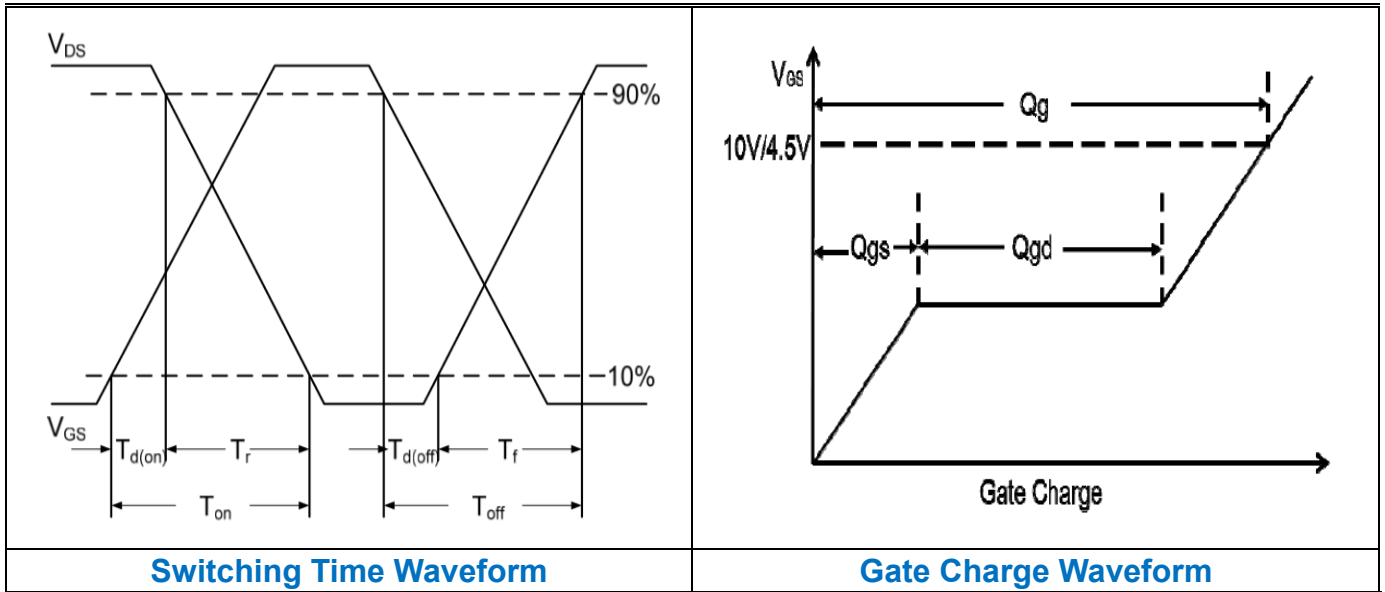

SOP8 PACKAGE INFORMATION

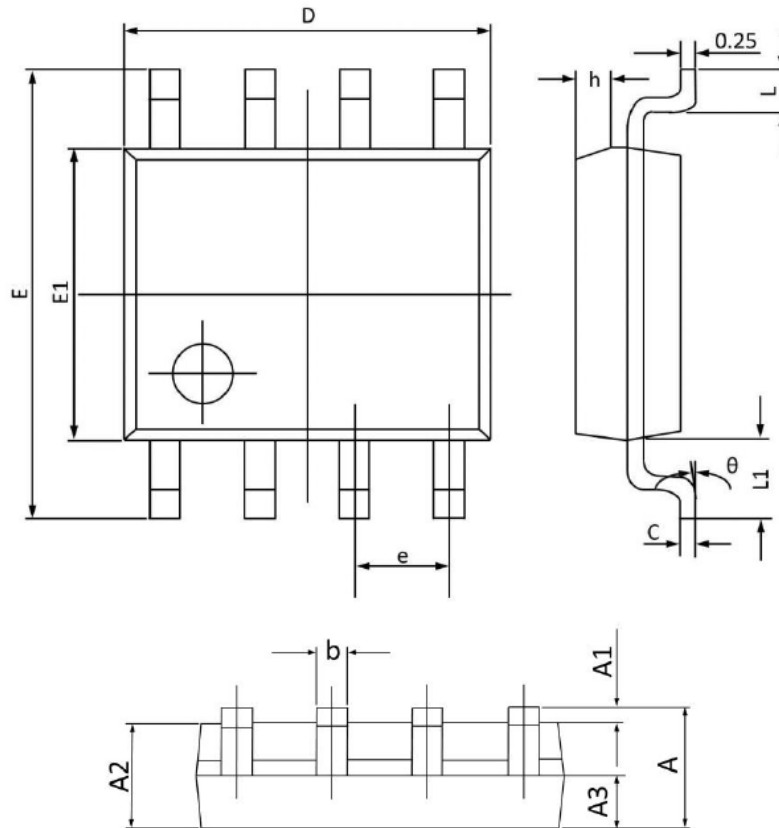

Symbol	Dimensions In Millimeters		Dimensions In Inches	
	MAX	MIN	MAX	MIN
A	1.750	1.350	0.068	0.053
A1	0.250	0.100	0.009	0.004
A2	1.500	1.300	0.059	0.052
A3	0.700	0.600	0.027	0.024
b	0.480	0.390	0.018	0.016
c	0.260	0.210	0.010	0.009
D	5.100	4.700	0.200	0.186
E	6.200	5.800	0.244	0.229
E1	4.100	3.700	0.161	0.146
e	1.270(BSC)		0.050(BSC)	
h	0.500	0.250	0.019	0.010
L	0.800	0.500	0.031	0.019
L1	1.050(BSC)		0.041(BSC)	
theta	8°	0°	8°	0°