

## N-Channel 65-V<sub>(D-S)</sub> SGT MOSFET

PRODUCT SUMMARY		
B <sub>VDSS</sub> (V)	R <sub>DS(on)</sub> (mΩ)(MAX)	I <sub>D</sub> (A)
65	16@V <sub>GS</sub> =10V	44

### PPAK5X6 Pin Configuration

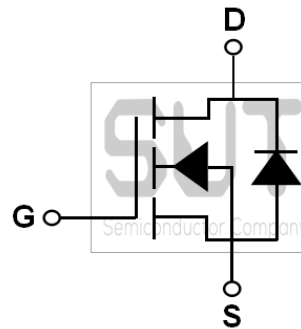

### ABSOLUTE MAXIMUM RATINGS(T<sub>C</sub>=25°C UNLESS OTHERWISE NOTED)

Parameter	Symbol	Rating	Units
Drain-Source Voltage	V <sub>DS</sub>	65	V
Gate-Source Voltage	V <sub>GS</sub>	+20/-12	V
Drain Current-Continuous (T <sub>C</sub> =25°C)	I <sub>D</sub>	44	A
Drain Current-Continuous (T <sub>C</sub> =100°C)		27	A
Drain Current-Pulsed <sup>1</sup>	I <sub>DM</sub>	176	A
Single Pulse Avalanche Energy <sup>2</sup>	EAS	9.1	mJ
Single Pulse Avalanche Current <sup>2</sup>	IAS	13.5	A
Power Dissipation (T <sub>C</sub> =25°C)	P <sub>D</sub>	54.3	W
Power Dissipation-Derate above 25°C		0.43	W/°C
Storage Temperature Range	T <sub>STG</sub>	-55 to 150	°C
Operating Junction Temperature Range	T <sub>J</sub>	-55 to 150	°C

### THERMAL CHARACTERISTICS

Parameter	Symbol	Typ.	Max.	Unit
Thermal Resistance Junction to ambient	R <sub>θJA</sub>	---	62	°C/W
Thermal Resistance Junction to Case	R <sub>θJC</sub>	---	2.3	°C/W

ELECTRICAL CHARACTERISTICS (T <sub>J</sub> =25°C UNLESS OTHERWISE NOTED)						
Parameter	Symbol	Test Condition	Min.	Typ.	Max.	Unit
<b>Off Characteristics</b>						
Drain-Source Breakdown Voltage	BV <sub>DSS</sub>	V <sub>GS</sub> =0V, I <sub>D</sub> =250uA	65	---	---	V
BV <sub>DSS</sub> Temperature Coefficient	ΔBV <sub>DSS</sub> /ΔT <sub>J</sub>	Reference to 25°C, I <sub>D</sub> =1mA	---	0.03	---	V/°C
Drain-Source Leakage Current	I <sub>DSS</sub>	V <sub>GS</sub> =0V, V <sub>DS</sub> =60V, T <sub>J</sub> =25°C	---	---	1	uA
		V <sub>GS</sub> =0V, V <sub>DS</sub> =48V, T <sub>J</sub> =85°C	---	---	10	uA
Gate-Source Leakage Current	I <sub>GSS</sub>	V <sub>GS</sub> =20V, V <sub>DS</sub> =0V	---	---	100	nA
<b>On Characteristics</b>						
Static Drain-Source On-Resistance	R <sub>DS(ON)</sub>	V <sub>GS</sub> =10V, I <sub>D</sub> =16A	---	13.6	16	mΩ
		V <sub>GS</sub> =4.5V, I <sub>D</sub> =12A	---	24.5	30	mΩ
Gate Threshold Voltage	V <sub>GS(th)</sub>	V <sub>GS</sub> =V <sub>DS</sub> , I <sub>D</sub> =250uA	1.0	1.6	2.5	V
V <sub>GS(th)</sub> Temperature Coefficient	ΔV <sub>GS(th)</sub>		---	-5.1	---	mV/°C
Forward Transconductance	g <sub>fs</sub>	V <sub>DS</sub> =10V, I <sub>D</sub> =3A	---	5.0	---	S
<b>Dynamic and Switching Characteristics</b>						
Total Gate Charge <sup>3, 4</sup>	Q <sub>g</sub>	V <sub>GS</sub> =10V, V <sub>DS</sub> =30V, I <sub>D</sub> =12A	---	10.9	22	nC
Gate-Source Charge <sup>3, 4</sup>	Q <sub>gs</sub>		---	1.5	3.0	
Gate-Drain Charge <sup>3, 4</sup>	Q <sub>gd</sub>		---	4.4	9.0	
Turn-On Delay Time <sup>3, 4</sup>	T <sub>d(on)</sub>	V <sub>GS</sub> =10V, V <sub>DD</sub> =30V, R <sub>G</sub> =3.3Ω, I <sub>D</sub> =1A	---	8.0	16	ns
Rise Time <sup>3, 4</sup>	T <sub>r</sub>		---	12	24	
Turn-Off Delay Time <sup>3, 4</sup>	T <sub>d(off)</sub>		---	25	50	
Fall Time <sup>3, 4</sup>	T <sub>f</sub>		---	18	36	
Input Capacitance	C <sub>iss</sub>	V <sub>GS</sub> =0V, V <sub>DS</sub> =30V, F=1MHz	---	653	1300	pF
Output Capacitance	C <sub>oss</sub>		---	192	380	
Reverse Transfer Capacitance	C <sub>rss</sub>		---	27	60	
Gate resistance	R <sub>g</sub>	V <sub>GS</sub> =0V, V <sub>DS</sub> =0V, F=1MHz	---	0.3	---	Ω
<b>Drain-Source Diode Characteristics and Maximum Ratings</b>						
Continuous Source Current	I <sub>S</sub>	V <sub>G</sub> =V <sub>D</sub> =0V, Force Current	---	---	44	A
Pulsed Source Current	I <sub>SM</sub>		---	---	88	A
Diode Forward Voltage	V <sub>SD</sub>	V <sub>GS</sub> =0V, I <sub>S</sub> =1A, T <sub>J</sub> =25°C	---	---	1.0	V

Note :

1. Repetitive Rating : Pulsed width limited by maximum junction temperature.
2. V<sub>GS</sub>=10V, V<sub>DD</sub>=50V, L=0.1mH, I<sub>AS</sub>=13.5A, R<sub>G</sub>=25Ω, Starting T<sub>J</sub>=25°C.
3. The data tested by pulsed, pulse width ≤ 300us, duty cycle ≤ 2%.
4. Essentially independent of operating temperature.

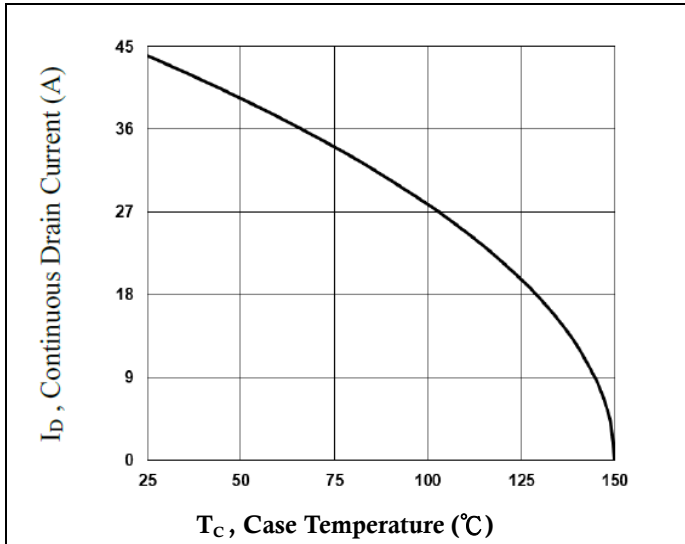

Continuous Drain Current vs.  $T_C$

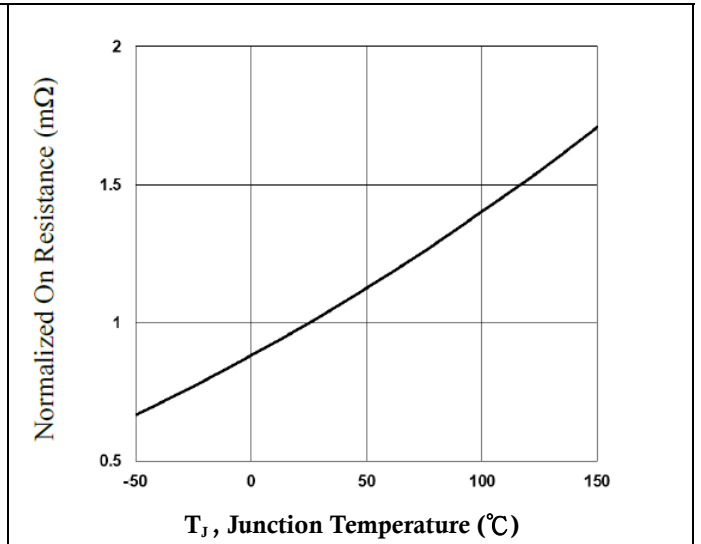

Normalized  $R_{DS(ON)}$  vs.  $T_J$

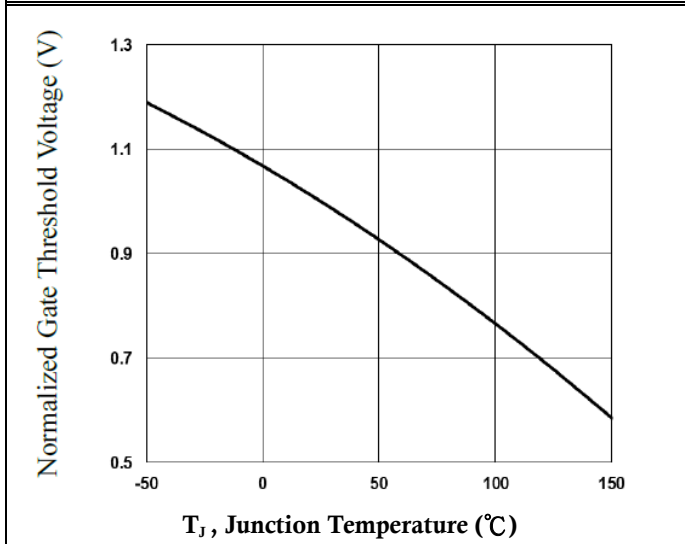

Normalized  $V_{th}$  vs.  $T_J$

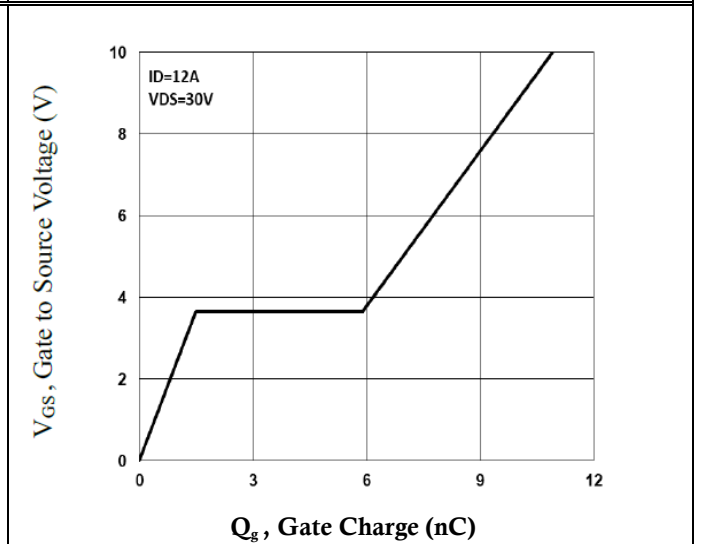

Gate Charge Waveform

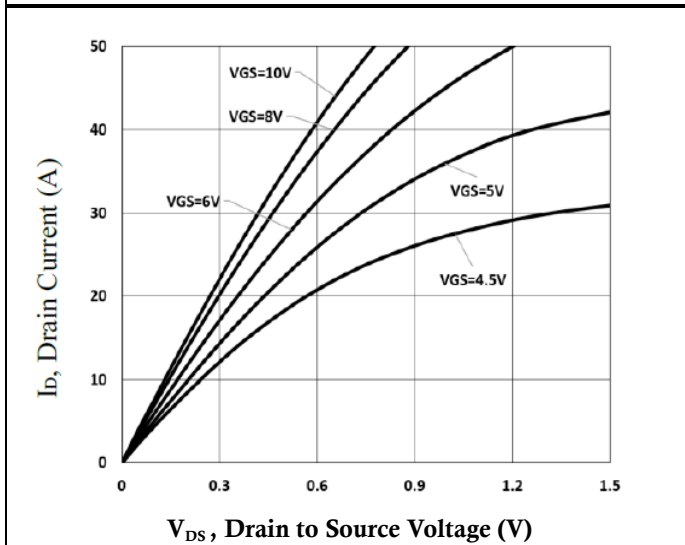

Typical Output Characteristics

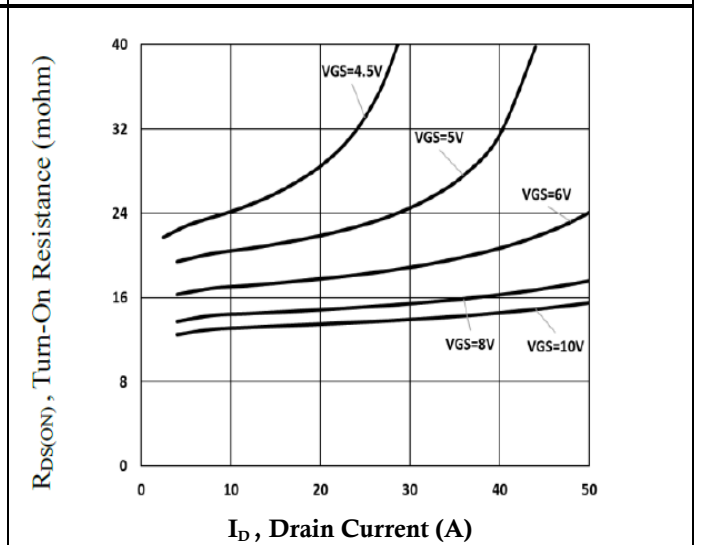

Turn-On Resistance vs.  $I_D$

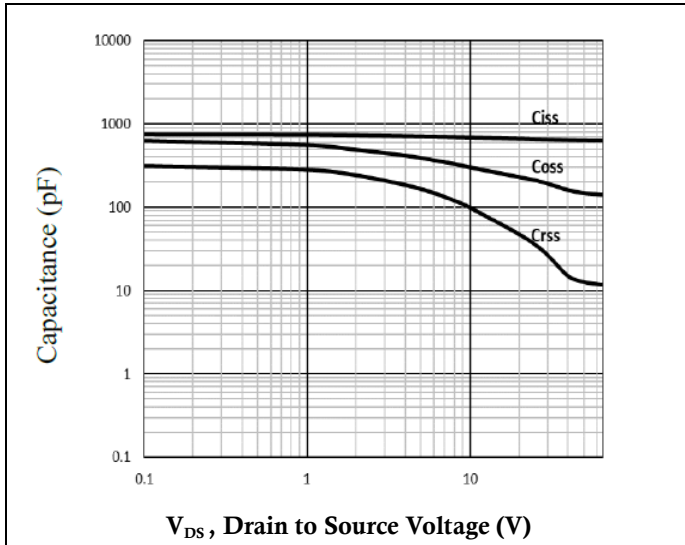

**Capacitance Characteristics**

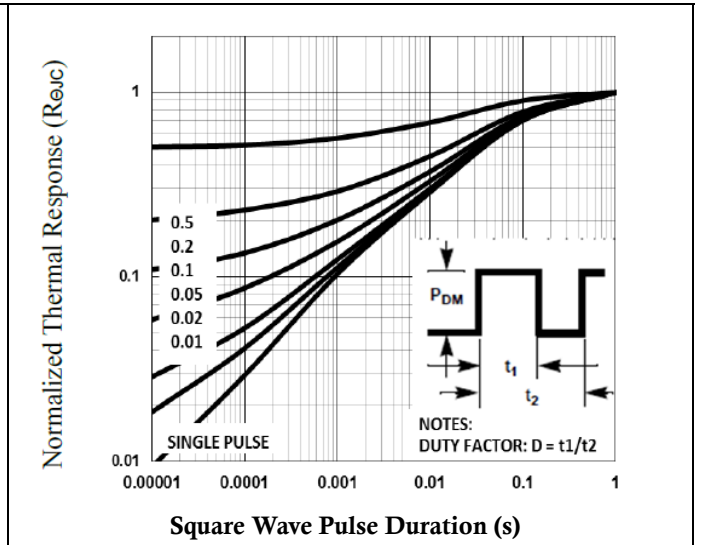

**Normalized Transient Response**

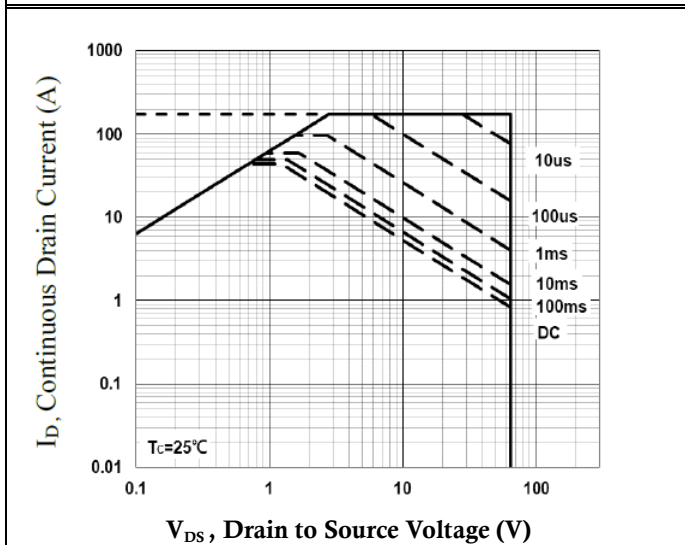

**Maximum Safe Operation Area**

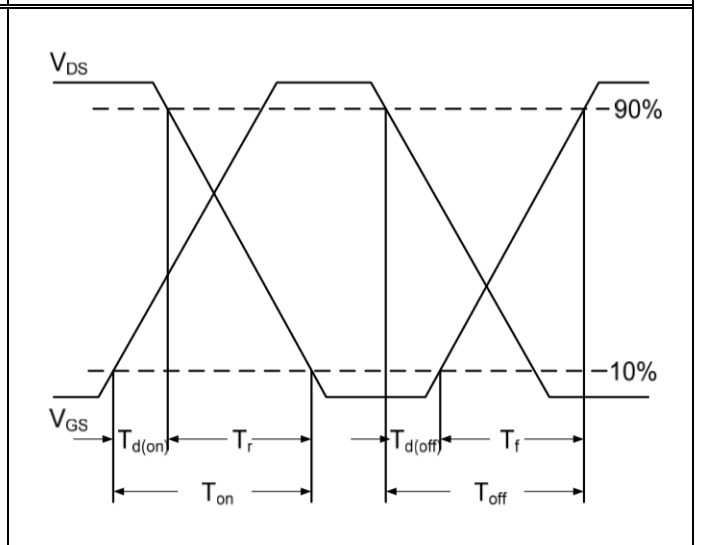

**Switching Time Waveform**

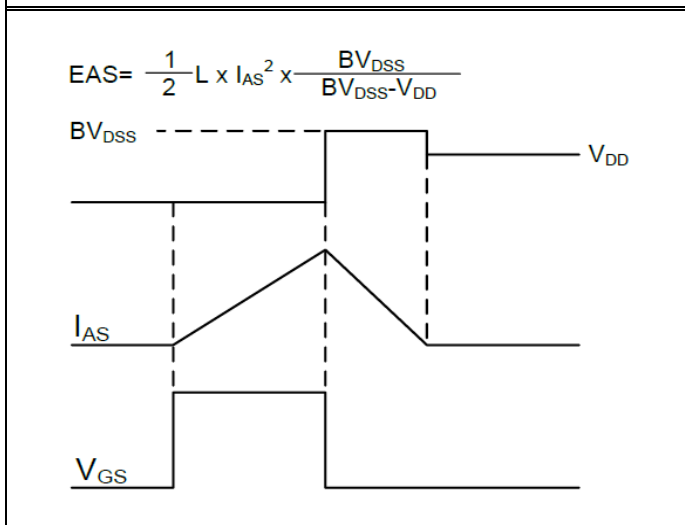

**EAS Waveform**

PPAK5X6 PACKAGE INFORMATION

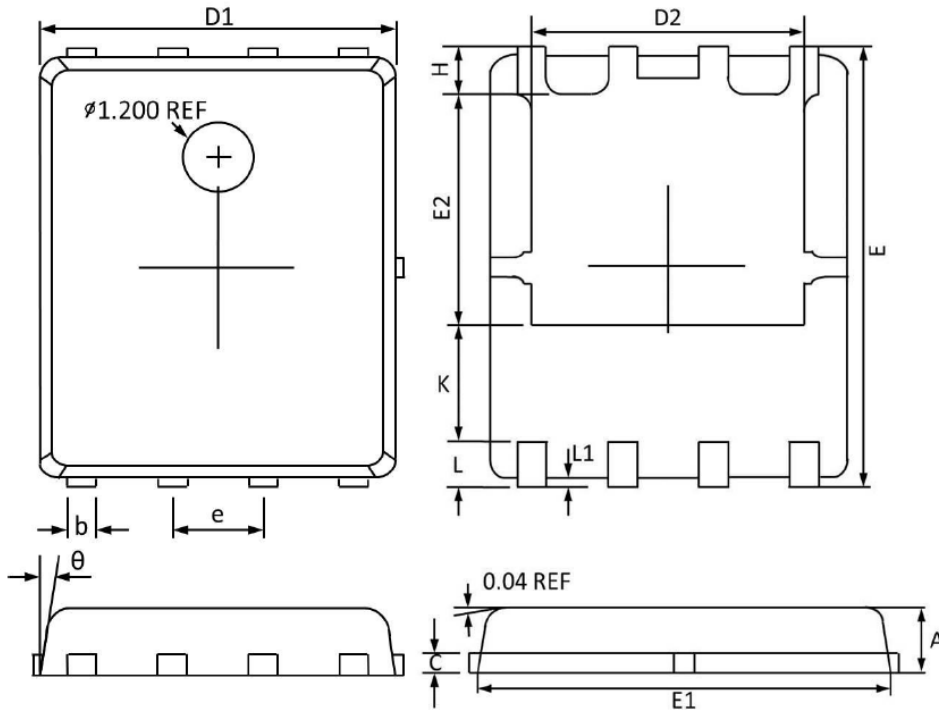

Symbol	Dimensions In Millimeters		Dimensions In Inches	
	MAX	MIN	MAX	MIN
A	1.100	0.800	0.043	0.031
b	0.510	0.330	0.020	0.013
C	0.300	0.200	0.012	0.008
D1	5.100	4.800	0.201	0.189
D2	4.100	3.610	0.161	0.142
E	6.200	5.900	0.244	0.232
E1	5.900	5.700	0.232	0.224
E2	3.780	3.350	0.149	0.132
e	1.270(BSC)		0.050(BSC)	
H	0.700	0.410	0.028	0.016
K	1.500	1.100	0.059	0.043
L	0.710	0.510	0.028	0.020
L1	0.200	0.060	0.008	0.002
theta	12°	0°	12°	0°