

P-Channel 30-V_(D-S) MOSFET

PRODUCT SUMMARY		
B _{VDSS} (V)	R _{DS(on)} (mΩ)(MAX)	I _D (A)
-30	50@V _{GS} =-10V	-5.5

SOP8 Pin Configuration

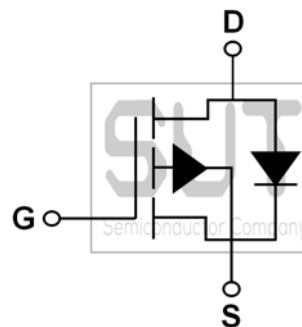
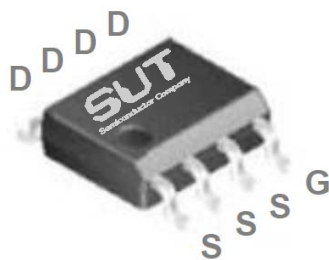

ABSOLUTE MAXIMUM RATINGS(T_C=25°C UNLESS OTHERWISE NOTED)

Parameter	Symbol	Rating	Units
Drain-Source Voltage	V _{DS}	-30	V
Gate-Source Voltage	V _{GS}	±20	V
Drain Current-Continuous (T _C =25°C)	I _D	-5.5	A
Drain Current-Continuous (T _C =100°C)		-3.48	A
Drain Current-Pulsed ¹	I _{DM}	-22	A
Power Dissipation (T _C =25°C)	P _D	2.1	W
Power Dissipation-Derate above 25°C		0.017	W/°C
Storage Temperature Range	T _{STG}	-55 to 150	°C
Operating Junction Temperature Range	T _J	-55 to 150	°C

THERMAL CHARACTERISTICS

Parameter	Symbol	Typ.	Max.	Unit
Thermal Resistance Junction to ambient	R _{θJA}	---	60	°C/W

ELECTRICAL CHARACTERISTICS (T _J =25°C UNLESS OTHERWISE NOTED)						
Parameter	Symbol	Test Condition	Min.	Typ.	Max.	Unit
Off Characteristics						
Drain-Source Breakdown Voltage	BV _{DSS}	V _{GS} =0V, I _D =-250uA	-30	---	---	V
BV _{DSS} Temperature Coefficient	ΔBV _{DSS} /ΔT _J	Reference to 25°C, I _D =-1mA	---	-0.03	---	V/°C
Drain-Source Leakage Current	I _{DSS}	V _{GS} =0V, V _{DS} =-30V, T _J =25°C	---	---	-1	uA
		V _{GS} =0V, V _{DS} =-24V, T _J =125°C	---	---	-10	uA
Gate-Source Leakage Current	I _{GSS}	V _{GS} =±20V, V _{DS} =0V	---	---	±100	nA
On Characteristics						
Static Drain-Source On-Resistance	R _{DS(ON)}	V _{GS} =-10V, I _D =-3A	---	40	50	mΩ
		V _{GS} =-4.5V, I _D =-2A	---	62	80	mΩ
Gate Threshold Voltage	V _{GS(th)}	V _{GS} =V _{DS} , I _D =-250uA	-1.0	-1.6	-2.5	V
V _{GS(th)} Temperature Coefficient	ΔV _{GS(th)}		---	4.0	---	mV/°C
Forward Transconductance	g _{fs}	V _{DS} =-10V, I _D =-3A	---	3.5	---	S
Dynamic and Switching Characteristics						
Total Gate Charge ^{2, 3}	Q _g	V _{GS} =-4.5V, V _{DS} =-15V, I _D =-3A	---	5.1	7.0	nC
Gate-Source Charge ^{2, 3}	Q _{gs}		---	2.0	3.0	
Gate-Drain Charge ^{2, 3}	Q _{gd}		---	2.2	4.0	
Turn-On Delay Time ^{2, 3}	T _{d(on)}	V _{GS} =-10V, V _{DD} =-15V, R _G =6Ω, I _D =-1A	---	3.4	6.0	ns
Rise Time ^{2, 3}	T _r		---	10.8	21	
Turn-Off Delay Time ^{2, 3}	T _{d(off)}		---	26.9	51	
Fall Time ^{2, 3}	T _f		---	6.9	13	
Input Capacitance	C _{iss}	V _{GS} =0V, V _{DS} =-15V, F=1MHz	---	560	810	pF
Output Capacitance	C _{oss}		---	55	80	
Reverse Transfer Capacitance	C _{rss}		---	40	60	
Drain-Source Diode Characteristics and Maximum Ratings						
Continuous Source Current	I _S	V _G =V _D =0V, Force Current	---	---	-5.5	A
Pulsed Source Current	I _{SM}		---	---	-11	A
Diode Forward Voltage	V _{SD}	V _{GS} =0V, I _S =-1A, T _J =25°C	---	---	-1.0	V

Note :

1. Repetitive Rating : Pulsed width limited by maximum junction temperature.
2. The data tested by pulsed , pulse width ≤ 300us , duty cycle ≤ 2%.
3. Essentially independent of operating temperature.

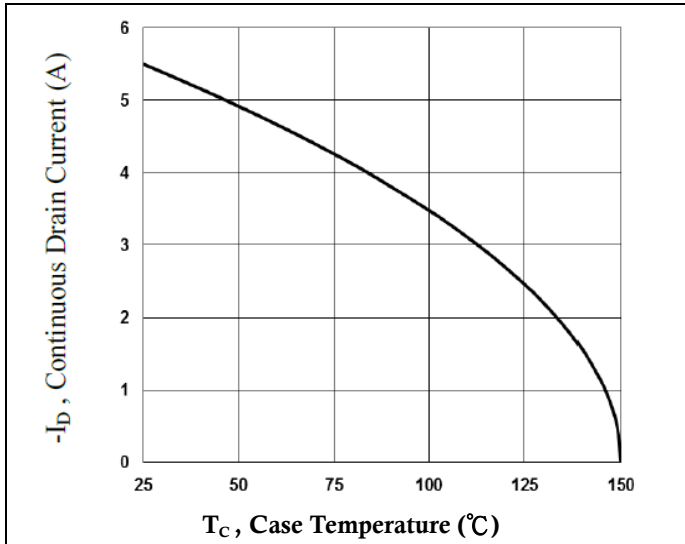

Continuous Drain Current vs. T_C

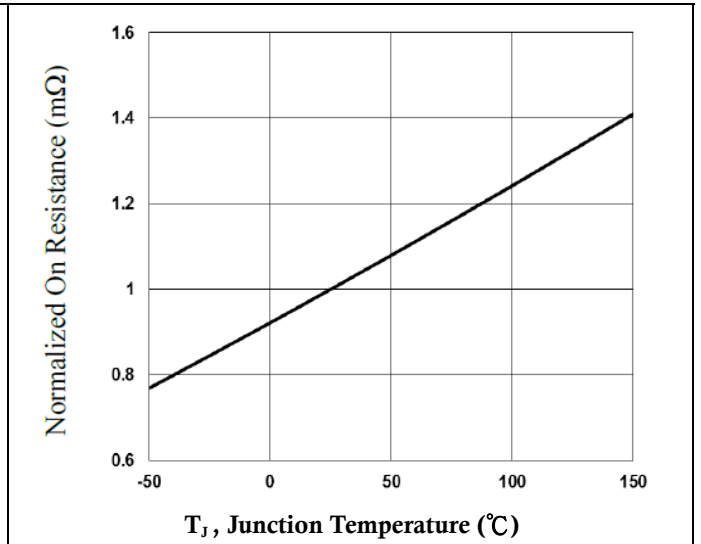

Normalized R_{DS(ON)} vs. T_J

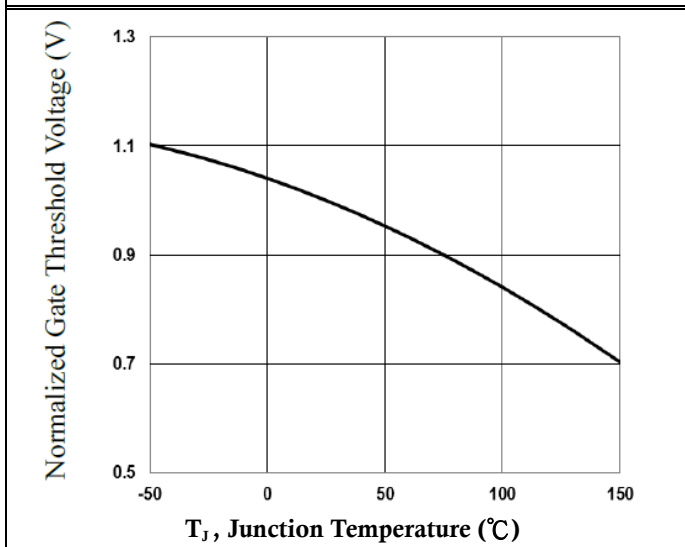

Normalized V_{th} vs. T_J

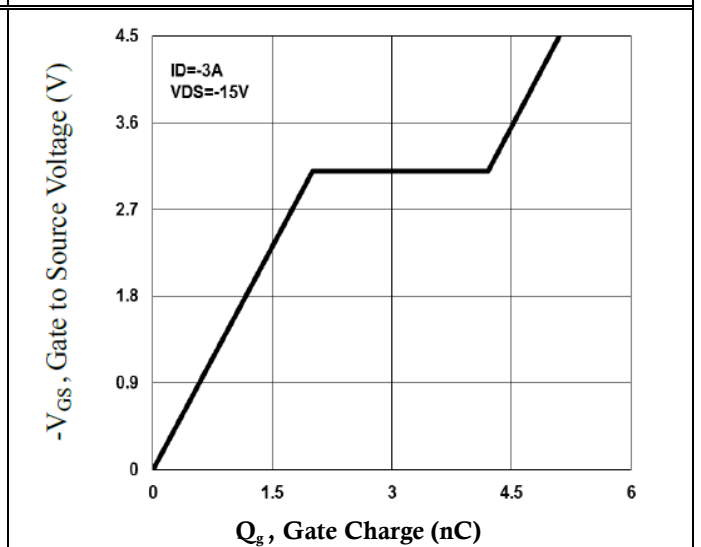

Gate Charge Waveform

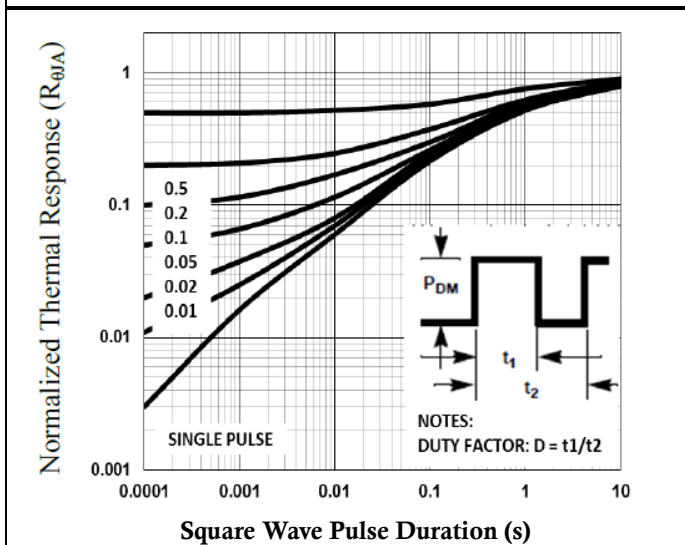

Normalized Transient Impedance

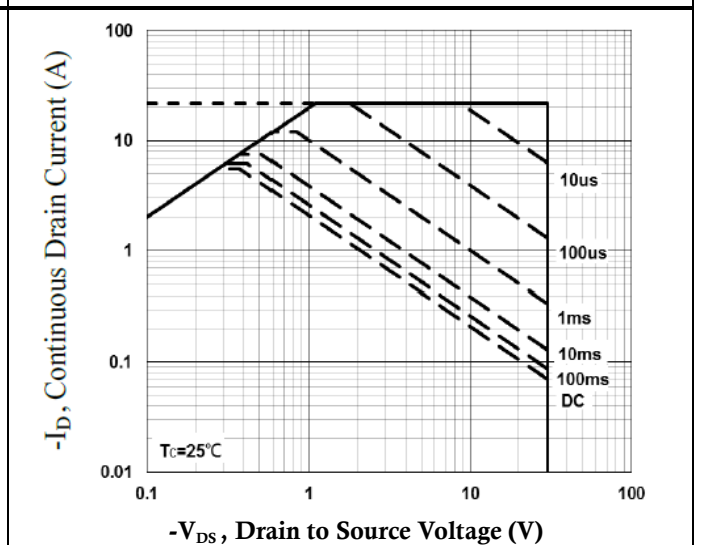

Maximum Safe Operation Area

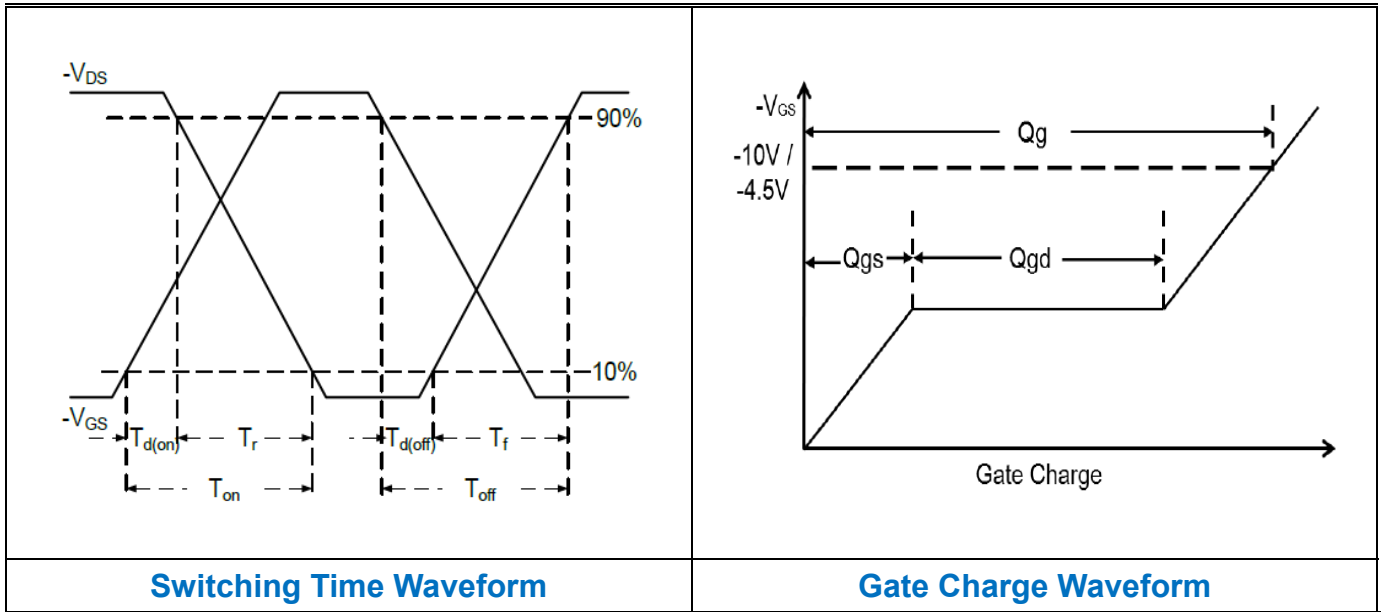

SOP8 PACKAGE INFORMATION

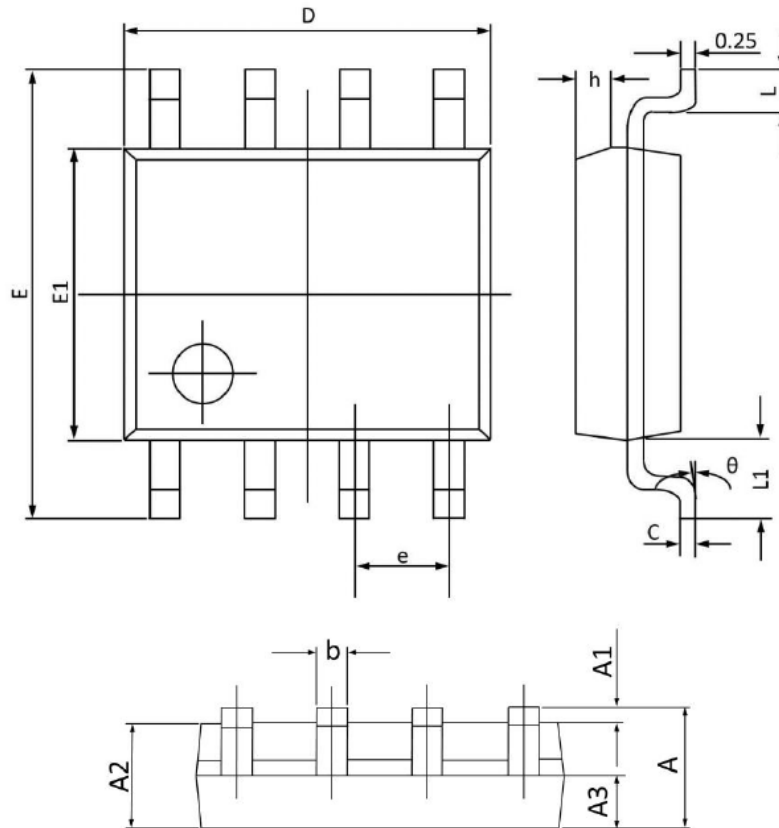

Symbol	Dimensions In Millimeters		Dimensions In Inches	
	MAX	MIN	MAX	MIN
A	1.750	1.350	0.068	0.053
A1	0.250	0.100	0.009	0.004
A2	1.500	1.300	0.059	0.052
A3	0.700	0.600	0.027	0.024
b	0.480	0.390	0.018	0.016
c	0.260	0.210	0.010	0.009
D	5.100	4.700	0.200	0.186
E	6.200	5.800	0.244	0.229
E1	4.100	3.700	0.161	0.146
e	1.270(BSC)		0.050(BSC)	
h	0.500	0.250	0.019	0.010
L	0.800	0.500	0.031	0.019
L1	1.050(BSC)		0.041(BSC)	
theta	8°	0°	8°	0°